

WORKS BARGE
GENERAL ARRANGEMENT

BY CT DATE JUNE '08 SCALE 1:20 @ A1 DRWG 33-01
 ISSUE 3

THIS DRAWING MAY NOT BE COPIED, COMMUNICATED TO ANY PERSON OR USED FOR MANUFACTURE WITHOUT THE EXPRESS WRITTEN CONSENT OF THE DESIGNER.

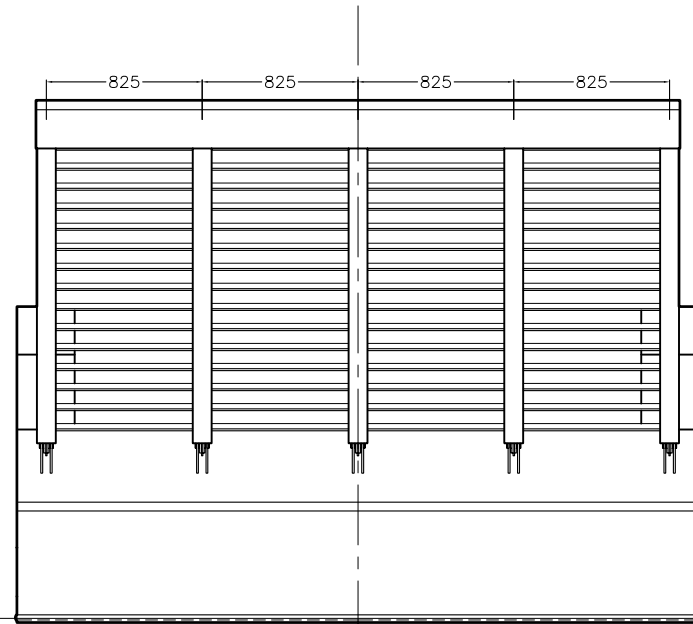

BOW VIEW
 SCALE 1:20

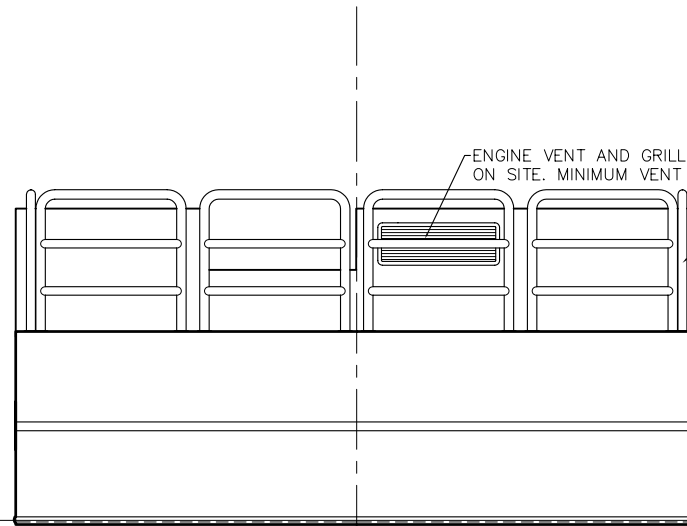

TRANSOM VIEW
 SCALE 1:20

ENGINE VENT AND GRILL TO BE SPECIFIED ON SITE. MINIMUM VENT AREA = 10 000mm²

DIA 50 REMOVABLE ALUMINIUM RAILS IN MIN 125mm DEEP SEALED SOCKETS WELDED INTO DECK. FIT PLASTIC CAPS TO RAIL AND/OR SOCKET ENDS.

NOTE: IF BUILDING TO SURVEY ELECTRIC BILGE PUMPS SHOULD BE AUGMENTED WITH 2 MANUAL PUMPS EACH WITH A 5.5KL/H CAPACITY

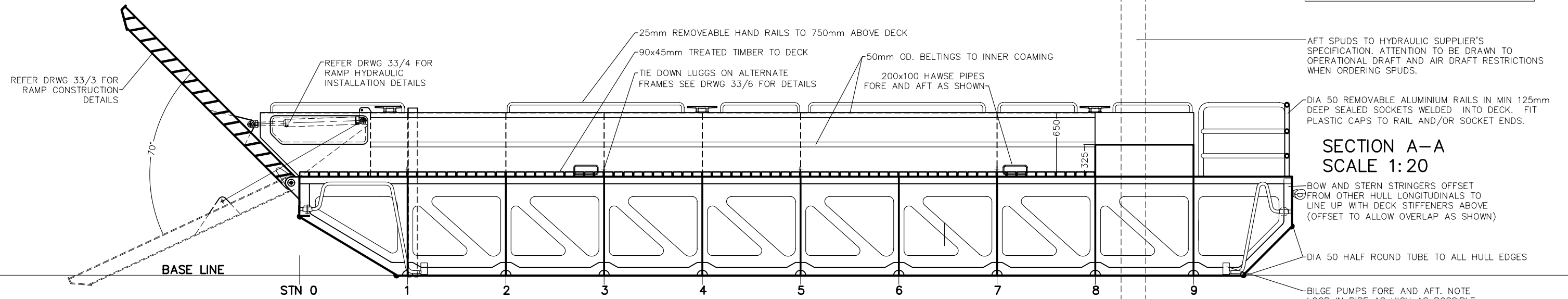

SECTION A-A
 SCALE 1:20

REFER DRWG 33/3 FOR RAMP CONSTRUCTION DETAILS

REFER DRWG 33/4 FOR RAMP HYDRAULIC INSTALLATION DETAILS

25mm REMOVEABLE HAND RAILS TO 750mm ABOVE DECK

90x45mm TREATED TIMBER TO DECK

TIE DOWN LUGGS ON ALTERNATE FRAMES SEE DRWG 33/6 FOR DETAILS

50mm OD. BELTINGS TO INNER COAMING

200x100 HAWSE PIPES FORE AND AFT AS SHOWN

AFT SPUDS TO HYDRAULIC SUPPLIER'S SPECIFICATION. ATTENTION TO BE DRAWN TO OPERATIONAL DRAFT AND AIR DRAFT RESTRICTIONS WHEN ORDERING SPUDS.

DIA 50 REMOVABLE ALUMINIUM RAILS IN MIN 125mm DEEP SEALED SOCKETS WELDED INTO DECK. FIT PLASTIC CAPS TO RAIL AND/OR SOCKET ENDS.

BOW AND STERN STRINGERS OFFSET FROM OTHER HULL LONGITUDINALS TO LINE UP WITH DECK STIFFENERS ABOVE (OFFSET TO ALLOW OVERLAP AS SHOWN)

DIA 50 HALF ROUND TUBE TO ALL HULL EDGES

BILGE PUMPS FORE AND AFT. NOTE LOOP IN PIPE AS HIGH AS POSSIBLE UNDER DECK.

4mm CHECK PLATE TO PEDESTRIAN DECKS

5mm SOFT PATCH OVER HYDRAULIC FITTINGS

PLAN VIEW
 SCALE 1:20

STORAGE RACK FOR 85mm ST. ST. MANUAL SPUD.

WATER TIGHT HATCH TO BUILDER'S PREFERRED SPECIFICATION

PINTLE HOOK TO VESSEL CL

WATER TIGHT ACCESS HATCHES TO BUILDER'S PREFERRED DETAIL.

REMOVABLE PILE GUIDES (DIA 150 & 200) WITH ROLLERS.

OPEN ANCHOR WELL

OPEN ANCHOR WELL

6x 300mm "HEAVY DUTY" ALUMINIUM DECK CLEATS

DECK STORAGE PORT AND STBD

HYDRAULIC CONTROL STATION TO SUPPLIER'S SPECIFICATION

A

C

C

A

3600